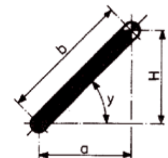
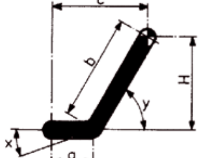
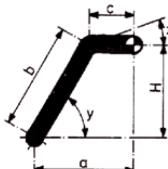
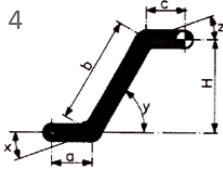
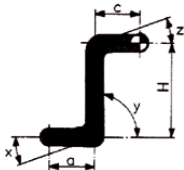
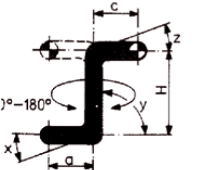

## Questionnaire for Sidewall belt calculations

BASIC INFORMATION	
Company	
Type	<input type="checkbox"/> User <input type="checkbox"/> OEM/ Eng. <input type="checkbox"/> Agent <input type="checkbox"/> Consultant
Contact Person	
Phone	Email
Fax	Date

CONFIGURATION	
Distance (a)	m
Angle (x)	°
Distance (b)	m
Angle (y)	°
Distance (c)	m
Angle (z)	°
Conveyor height (H)	m

MATERIAL	
Material	
Max. Lump size	mm
Capacity tonnage	to/h
Capacity volume	m <sup>3</sup> /h
Density	t/m <sup>3</sup>
Temperature max.	C°
Oil / fat	<input type="checkbox"/> Yes <input type="checkbox"/> No
Repose angle	°
Moisture	%
Belt width	mm
Sidewall height	mm
Belt speed	m/sec

CONFIGURATION TYPE	
<input type="checkbox"/> 1	
<input type="checkbox"/> 2	
<input type="checkbox"/> 3	
<input type="checkbox"/> 4	
<input type="checkbox"/> 5	
<input type="checkbox"/> 6	
Sketch	

NOTES

Please fill out the form, save as word or pdf file and send back to us.